

プルダウンクランプ

EA637HC-10~22

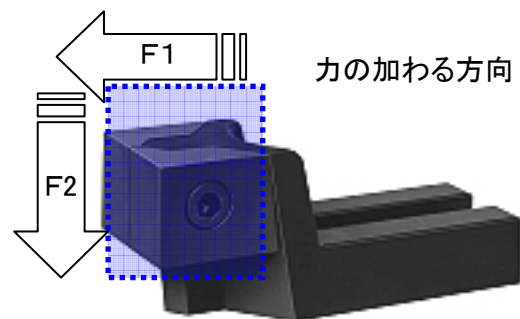

2個入り

品番	サイズ										重量(g)	
	適合T溝	B1	B2	C	H1	H2	H3	L1	L2	F1		F2
										[kN]		[kN]
EA637HC-10	10, 12, 14	13	40	3	50	20	30	115	60	6, 10, 15	0.2, 0.4, 0.6	1590
EA637HC-16	16, 18, 20	19	50	4	60	25	35	150	72	20, 28, 36	0.8, 1.1, 1.4	2940
EA637HC-22	22, 24, 28, 30, 32, 36	31	80	5	75	30	45	205	102	38, 38, 40, 40, 44, 44	1.5, 1.5, 1.6, 1.6, 1.7, 1.7	7900

単位:mm

●材質…焼入鋼